

Ampco Centrifugal Pumps

DATA SHEET

MODEL DC2 2 1/2 X2
MODEL DC3 2 1/2 X2

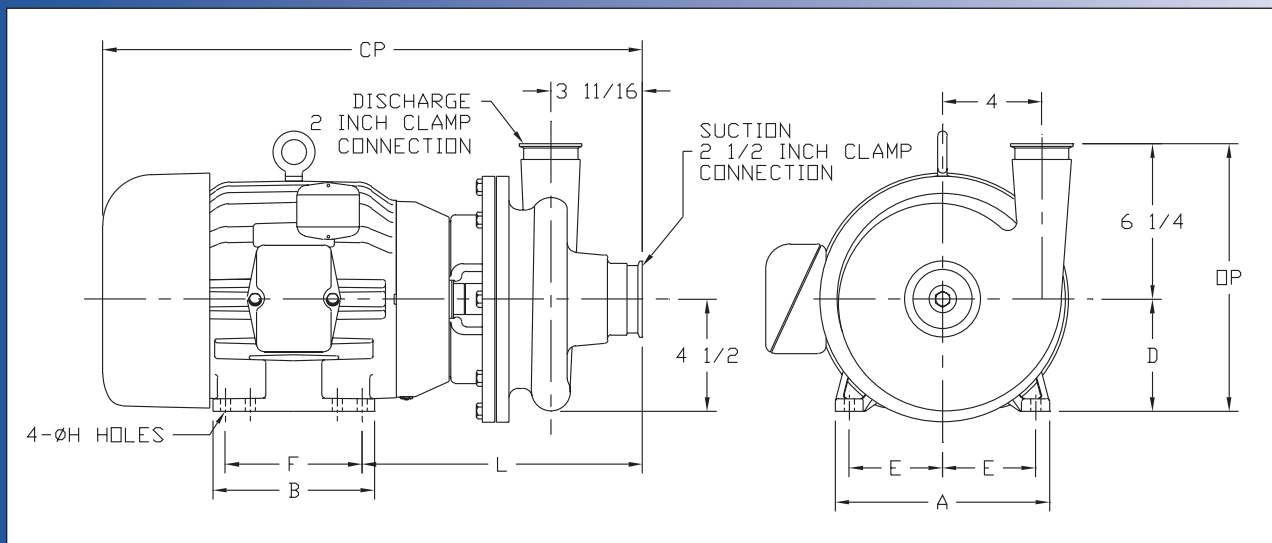
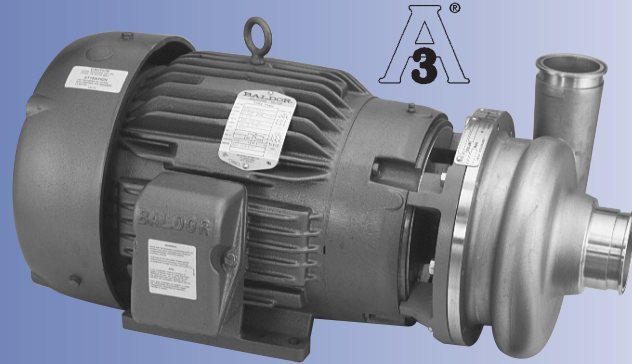

TEFC MOTOR			DIMENSIONS IN INCHES (For Reference Only)									APPROX. WEIGHT (LBS)
HP	RPM	FRAME	A (typ)	B (typ)	D	E	F	H	L	CP	OP	
1	1750	143JM	6-1/2	6	3-1/2	2-3/4	4	11/32	10-25/32	19-3/32	9-3/4	101
1-1/2	1750	145JM	6-1/2	6	3-1/2	2-3/4	5	11/32	10-25/32	19-3/32	9-3/4	105
2	1750	145JM	6-1/2	6	3-1/2	2-3/4	5	11/32	10-25/32	19-3/32	9-3/4	111
3	1750	182JM	8-5/8	6-1/2	4-1/2	3-3/4	4-1/2	13/32	11-3/8	20-15/32	10-3/4	129
5	3500	184JM	8-5/8	6-1/2	4-1/2	3-3/4	5-1/2	13/32	11-3/8	21-27/32	10-3/4	153
7-1/2	3500	213JM	9-5/8	8-1/8	5-1/4	4-1/4	5-1/2	13/32	12-5/32	24-23/32	11-1/2	217
10	3500	215JM	9-5/8	8-1/8	5-1/4	4-1/4	7	13/32	12-5/32	24-23/32	11-1/2	235
15	3500	215JM	9-1/8	8	5-1/4	4-1/4	7	13/32	12-13/32	24-19/32	11-1/2	332

MATERIAL SPECIFICATIONS

PART NAME	STAINLESS STEEL
Casing & Cover	316 Stainless
Impeller	316 Stainless
Motor Shaft	Steel
Shaft Sleeve	316 Stainless
Adapter	Cast Iron



Ampco Centrifugal Pumps

MODEL DC2 2½ X 2
MODEL DC3 2½ X 2

Curves show approximate characteristics based on clear 68° water. Rated point is guaranteed.

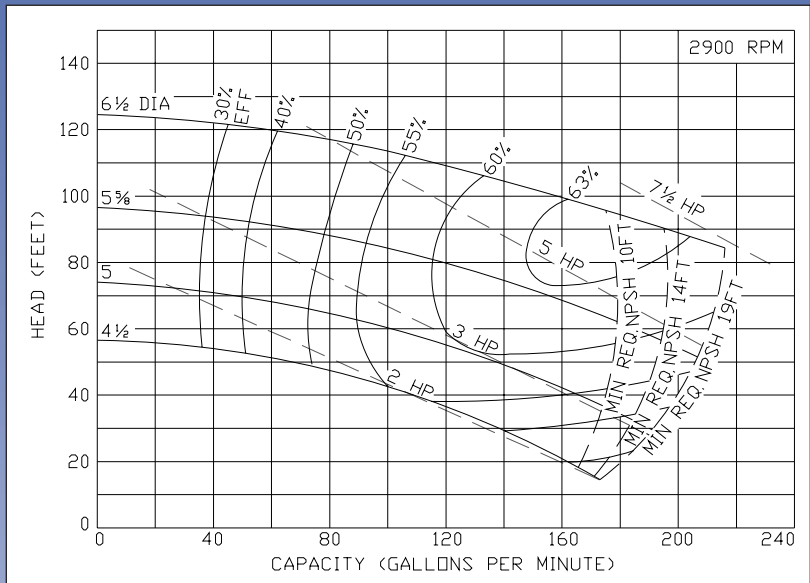
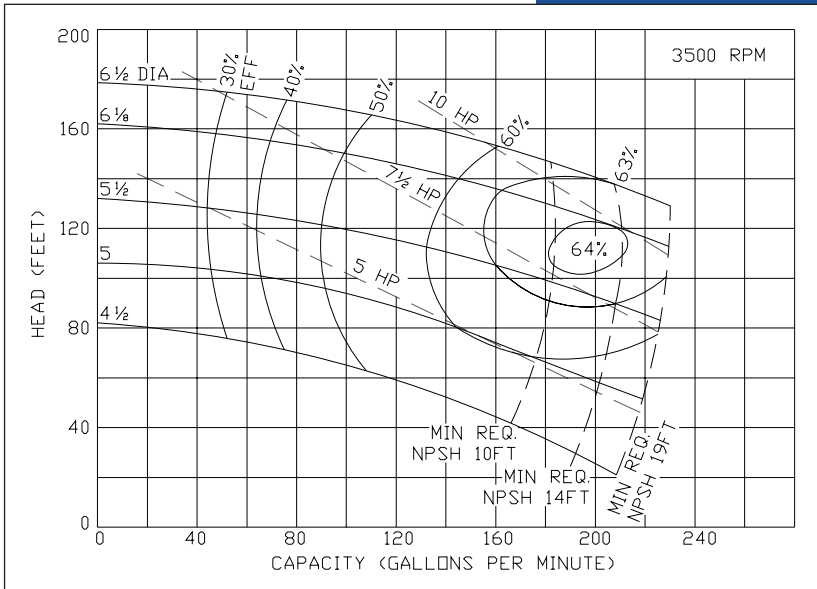

DC3/DCH3 pumps are in conformance with 3A sanitary standards for centrifugal and positive rotary pumps for pumping cleaning and sanitizing solutions, Number 47-00.

DC2/DCH2 pumps are also available with 150 lb. flat faced flanged connections.

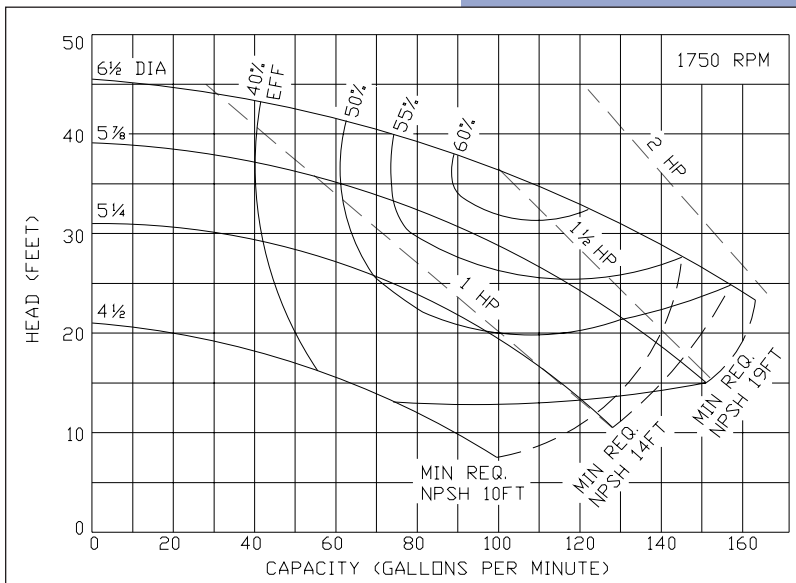

Ampco Pumps Company

4424 West Mitchell Street
Milwaukee, Wisconsin 53214
PHONE (414) 643-1852
FAX (414) 643-4452

Ampco Centrifugal Pumps

DATA SHEET

MODEL DC2/DCH2 3X2 1/2
MODEL DC3/DCH3 3X2 1/2

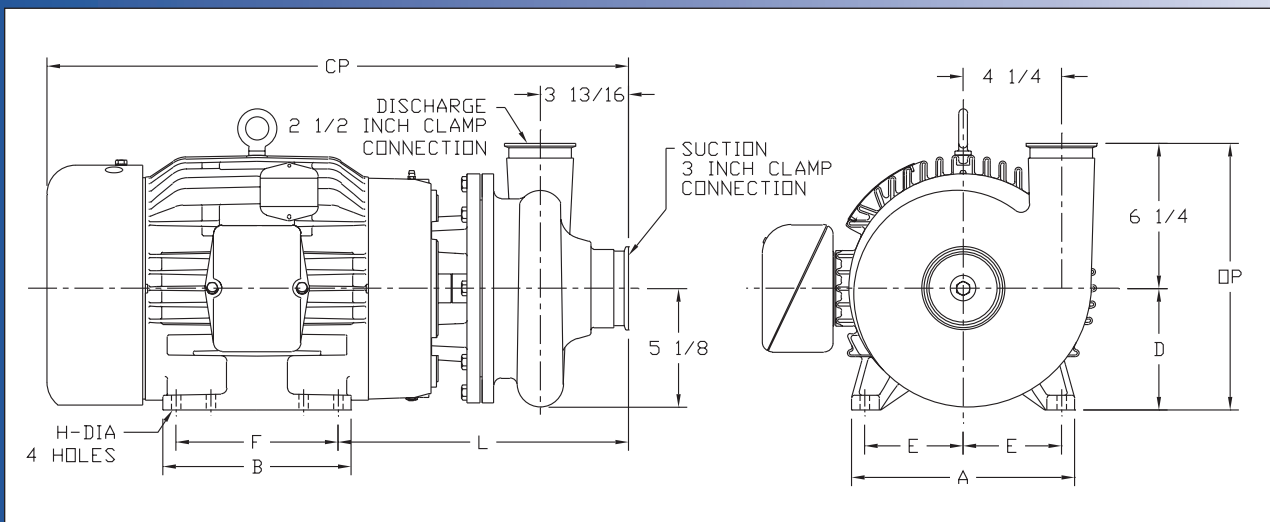
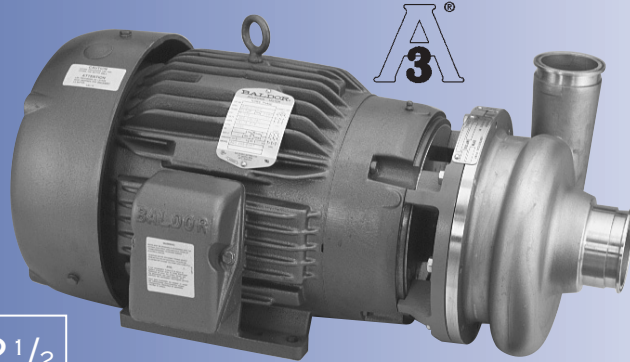

	TEFC MOTOR			DIMENSIONS IN INCHES (For Reference Only)									APPROX. WEIGHT (LBS)
	HP	RPM	FRAME	A (typ)	B (typ)	D	E	F	H	L	CP	OP	
DC2	1	1750	143JM	6-1/2	6	3-1/2	2-3/4	4	11/32	11-5/32	19-15/32	9-3/4	115
DC2	1-1/2	1750	145JM	6-1/2	6	3-1/2	2-3/4	5	11/32	11-5/32	19-15/32	9-3/4	119
DC2	2	1750	145JM	6-1/2	6	3-1/2	2-3/4	5	11/32	11-5/32	19-15/32	9-3/4	125
DC2	3	1750	182JM	8-5/8	6-1/2	4-1/2	3-3/4	4-1/2	13/32	11-25/32	20-27/32	10-3/4	143
DC2	5	3500	184JM	8-5/8	6-1/2	4-1/2	3-3/4	4-1/2	13/32	11-25/32	22-7/32	10-3/4	161
DC2	7-1/2	3500	213JM	9-5/8	8-1/8	5-1/4	4-1/4	5-1/2	13/32	12-25/32	25-3/32	11-1/2	224
DC2	10	3500	215JM	9-5/8	8-1/8	5-1/4	4-1/4	7	13/32	12-25/32	25-3/32	11-1/2	242
DCH2	15	3500	254JM	11-1/2	9-3/4	6-1/4	5	8-1/4	17/32	14-9/32	27-3/32	12-1/2	347
DCH2	20	3500	256JM	11-1/2	11-1/2	6-1/4	5	10	17/32	14-9/32	28-7/8	12-1/2	385
DCH2	25	3500	284JM	12-3/4	12-3/4	7	5-1/2	9-1/2	17/32	14-9/32	32-15/32	13-1/4	442

MATERIAL SPECIFICATIONS

PART NAME	STAINLESS STEEL
Casing & Cover	316 Stainless
Impeller	316 Stainless
Motor Shaft	Steel
Shaft Sleeve	316 Stainless
Adapter	Cast Iron

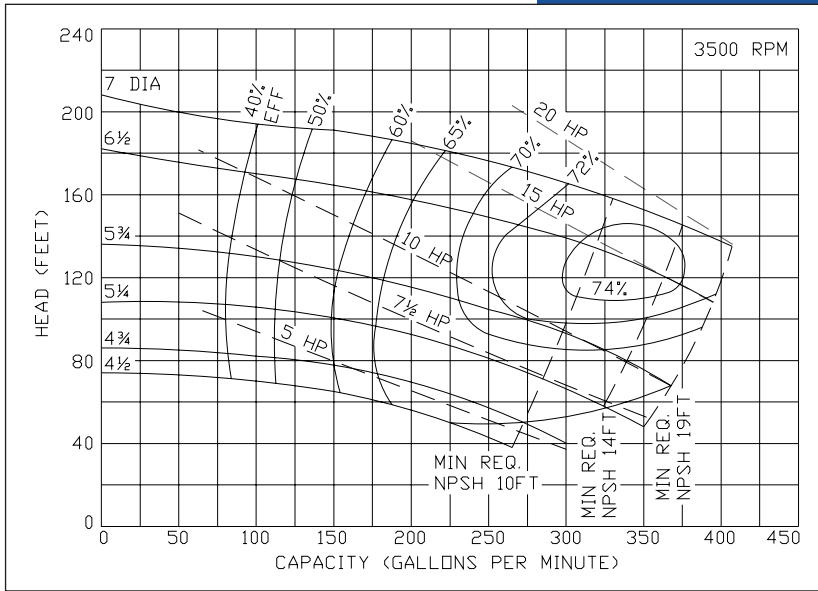

Ampco Centrifugal Pumps

MODEL DC2/DCH2 3X2¹/₂
 MODEL DC3/DCH3 3X2¹/₂

Curves show approximate characteristics based on clear 68° water. Rated point is guaranteed.

DC3/DCH3 pumps are in conformance with 3A sanitary standards for centrifugal and positive rotary pumps for pumping cleaning and sanitizing solutions, Number 47-00.

DC2/DCH2 pumps are also available with 150 lb. flat faced flanged connections.

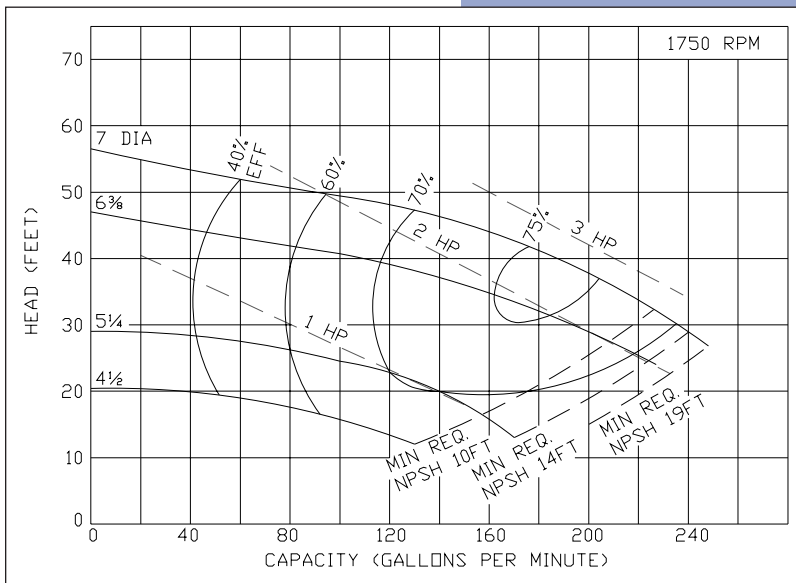
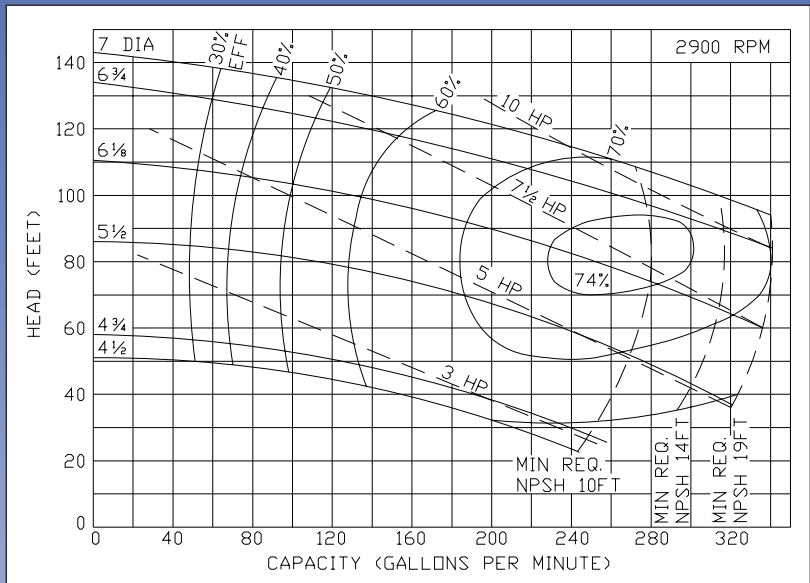

Ampco Pumps Company

4424 West Mitchell Street
 Milwaukee, Wisconsin 53214
 PHONE (414) 643-1852
 FAX (414) 643-4452

Ampco Centrifugal Pumps

DATA SHEET

MODEL DCH2 3X3
MODEL DCH3 3X3

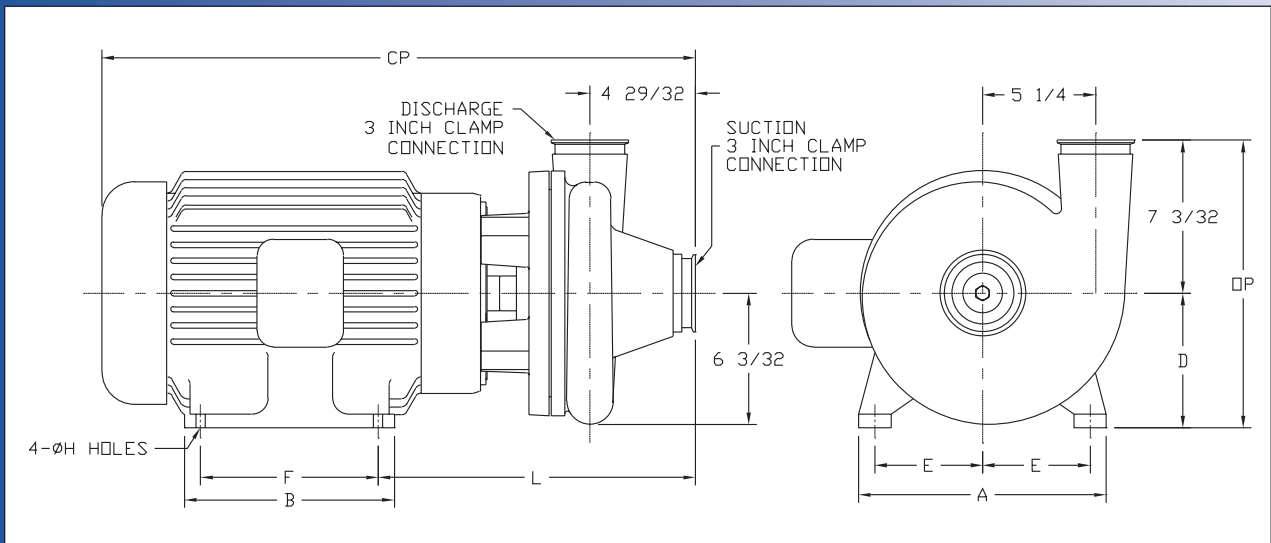
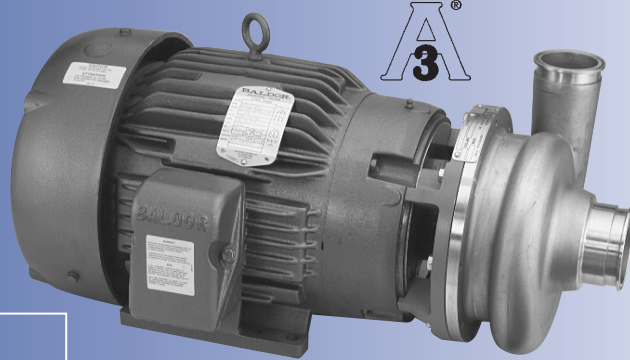

TEFC MOTOR			DIMENSIONS IN INCHES (For Reference Only)									APPROX. WEIGHT (LBS)
HP	RPM	FRAME	A (typ)	B (typ)	D	E	F	H	L	CP	OP	
2	1750	145JM	6-1/2	6	3-1/2	2-3/4	5	11/32	11-2/8	19-5/8	10-19/32	135
3	1750	182JM	8-5/8	6-1/2	4-1/2	3-3/4	4-1/2	13/32	11-7/8	21-5/8	11-19/32	141
5	1750	184JM	8-5/8	6-1/2	4-1/2	3-3/4	5-1/2	13/32	11-7/8	22-4/8	11-19/32	165
7.5	3500	213JM	9-5/8	8-1/8	5-1/4	4-1/4	5-1/2	13/32	12-7/8	25-2/8	12-11/32	234
10	3500	215JM	9-5/8	8-1/8	5-1/4	4-1/4	7	13/32	12-7/8	25-2/8	12-11/32	252
15	3500	254JM	11-1/2	9-3/4	6-1/4	5	8-1/4	17/32	14-4/82	27-2/8	13-11/32	373
20	3500	2564JM	11-1/2	11-1/2	6-1/4	5	10	17/32	14-4/8	29	13-11/32	412
25	3500	284JM	12-3/4	11-1/2	7	5-1/2	9-1/2	17/32	14-4/8	32-7/8	14-3/32	551
30	3500	286JM	12-3/4	12-3/4	7	5-1/2	11	17/32	14-4/8	32-7/8	14-3/32	670
40	3500	324JM	14-1/2	14	8	6-1/4	10-1/2	21/32	15	34-6/8	15-3/32	776

† Requires 210 Series motor having an 8-1/2" C-Flange face and shaft extension as per motor frame 254JM NEMA Standard MG-1-18.615 and Hydraulic Institute Standard.

MATERIAL SPECIFICATIONS

PART NAME	STAINLESS STEEL
Casing & Cover	316 Stainless
Impeller	316 Stainless
Motor Shaft	Steel
Shaft Sleeve	316 Stainless
Adapter	Cast Iron

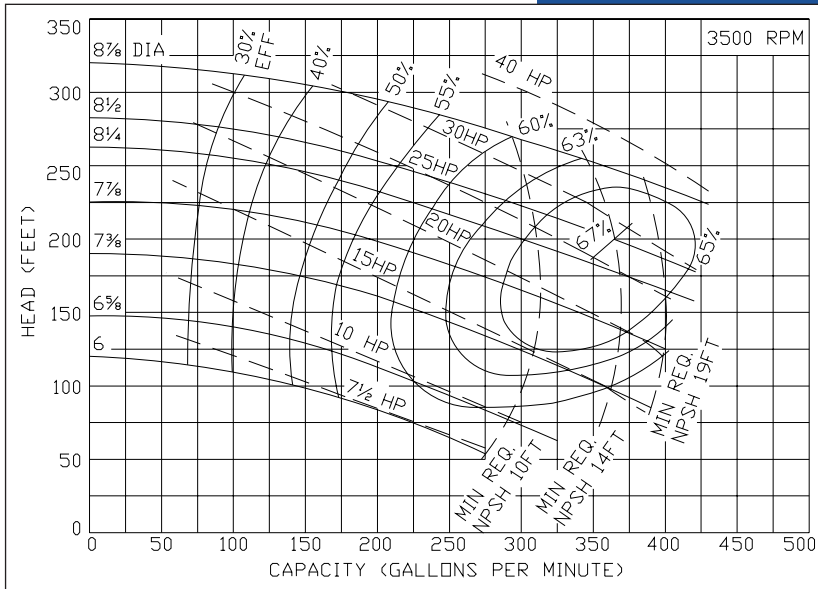

Ampco Centrifugal Pumps

**MODEL DCH2 3X3
MODEL DCH3 3X3**

Curves show approximate characteristics based on clear 68° water. Rated point is guaranteed.

DC3/DCH3 pumps are in conformance with 3A sanitary standards for centrifugal and positive rotary pumps for pumping cleaning and sanitizing solutions, Number 47-00.

DC2/DCH2 pumps are also available with 150 lb. flat faced flanged connections.

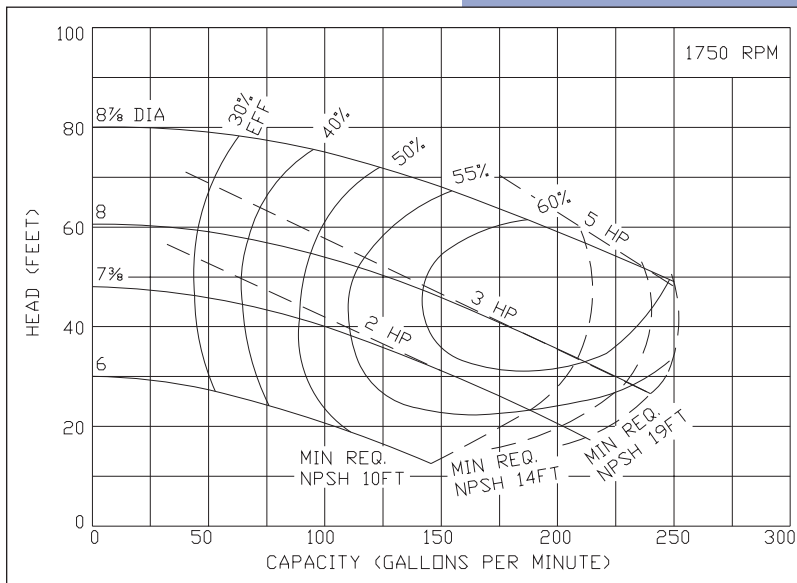
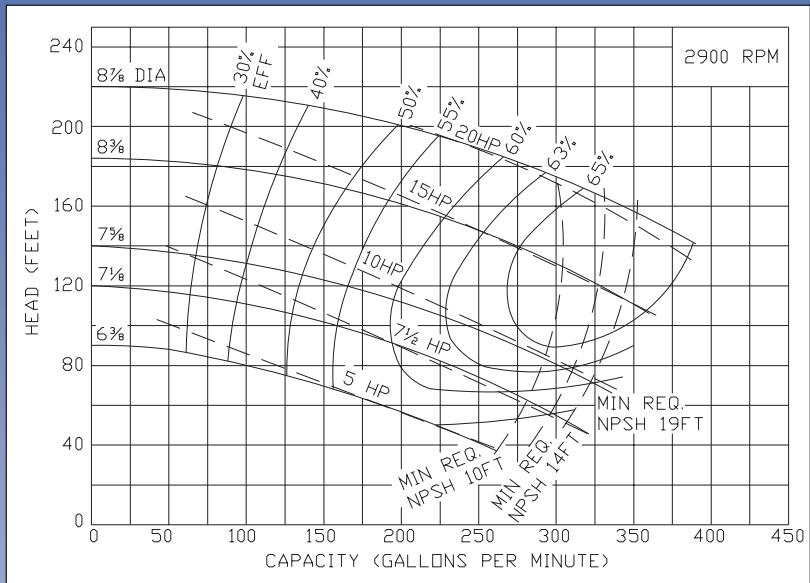

Ampco Pumps Company

4424 West Mitchell Street
Milwaukee, Wisconsin 53214
PHONE (414) 643-1852
FAX (414) 643-4452

Ampco Centrifugal Pumps

DATA SHEET

MODEL DC2/DCH2 4X3
MODEL DC3/DCH3 4X3

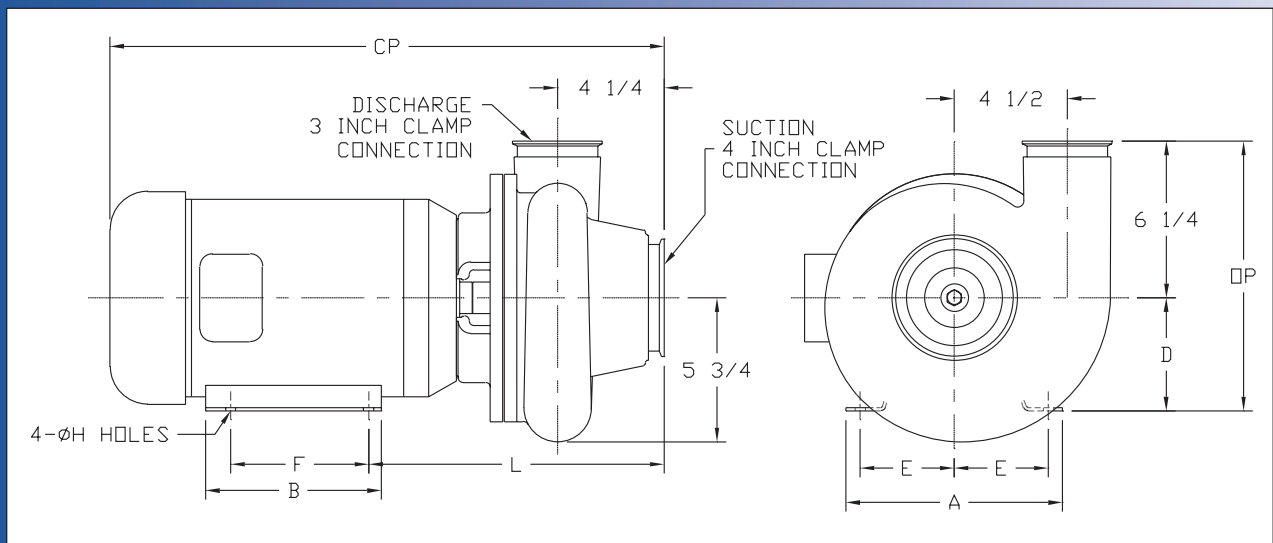
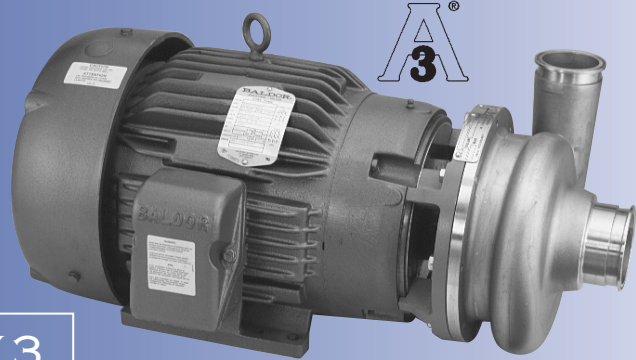

	TEFC MOTOR			DIMENSIONS IN INCHES (For Reference Only)									APPROX. WEIGHT (LBS)
	HP	RPM	FRAME	A (typ)	B (typ)	D	E	F	H	L	CP	OP	
DC2	2	1750	145JM	6-1/2	6	3-1/2	2-3/4	5	11/32	11-7/32	19-17/32	9-3/4	155
DC2	3	1750	182JM	8-5/8	6-1/2	4-1/2	3-3/4	5-1/2	13/32	11-27/32	20-29/32	10-3/4	167
DC2	5	1750	184JM	8-5/8	6-1/2	5-1/4	4-1/4	5-1/2	13/32	11-27/32	22-7/16	10-3/4	191
DC2	10	3500	215JM	9-1/2	8	5-1/4	4-1/4	7	13/32	12-27/32	23-5/32	11-1/2	258
DCH2	15	3500	254JM	11-1/2	9-3/4	6-1/4	5	8-1/4	17/32	14-11/32	27-5/32	12-1/2	379
DCH2	20	3500	256JM	11-1/2	11-1/2	6-1/4	5	10	17/32	14-11/32	29	12-1/2	398
DCH2	25	3500	284JM	12-3/4	12-3/4	7	5-1/2	9-1/2	9/16	14-11/32	32-17/32	13-1/4	533
DCH2	30	3500	286JM	12-3/4	12-3/4	7	5-1/2	11	9/16	14-11/32	33-5/32	13-1/4	662

MATERIAL SPECIFICATIONS

PART NAME	STAINLESS STEEL
Casing & Cover	316 Stainless
Impeller	316 Stainless
Motor Shaft	Steel
Shaft Sleeve	316 Stainless
Adapter	Cast Iron

Ampco Centrifugal Pumps

MODEL DC2/DCH2 4X3
MODEL DC3/DCH3 4X3

Curves show approximate characteristics based on clear 68° water. Rated point is guaranteed.

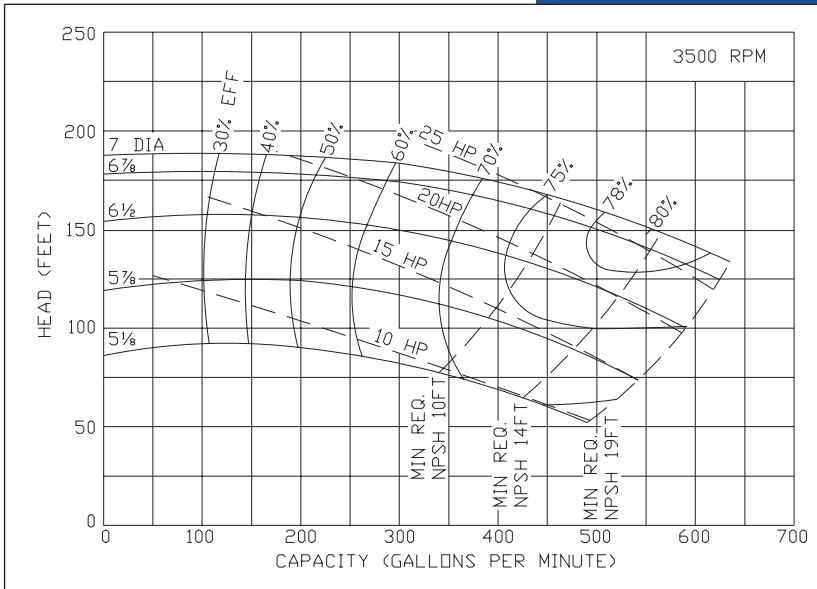

DC3/DCH3 pumps are in conformance with 3A sanitary standards for centrifugal and positive rotary pumps for pumping cleaning and sanitizing solutions, Number 47-00.

DC2/DCH2 pumps are also available with 150 lb. flat faced flanged connections.

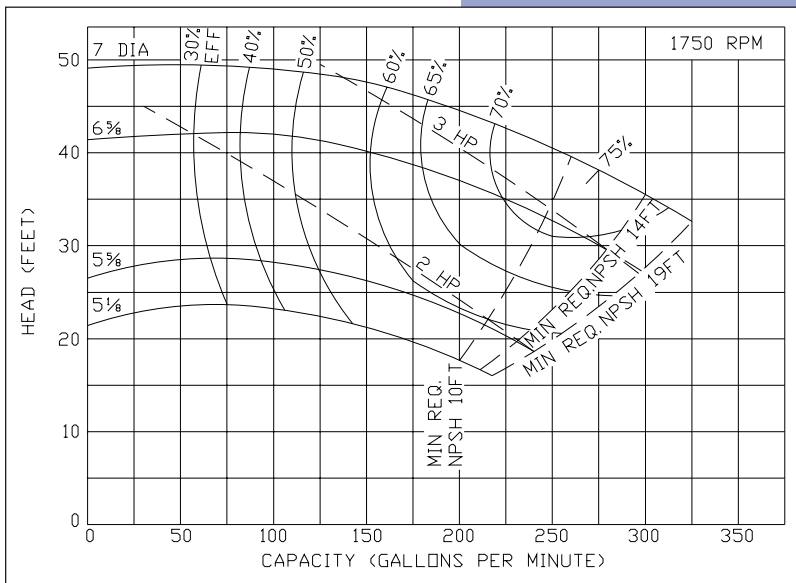
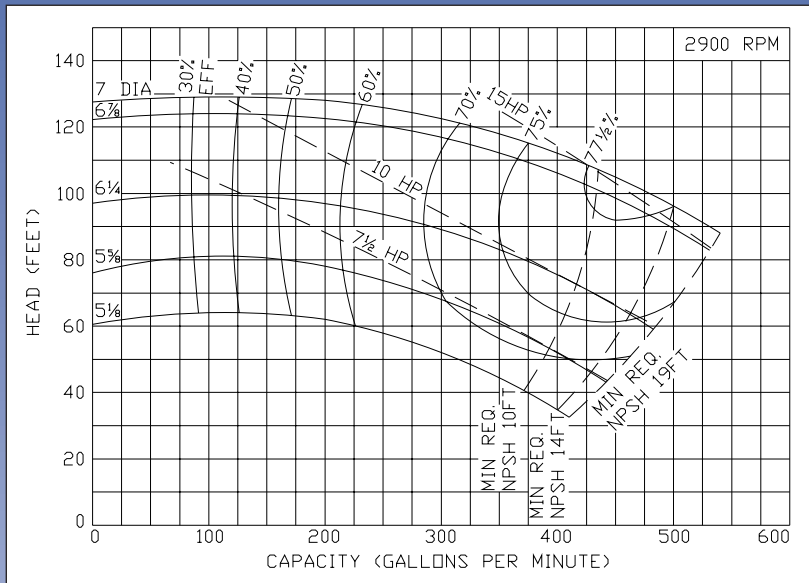

Ampco Pumps Company

4424 West Mitchell Street
Milwaukee, Wisconsin 53214
PHONE (414) 643-1852
FAX (414) 643-4452